

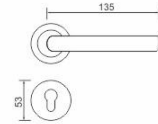

S-01 SS

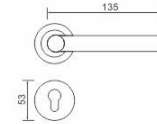

S-05 SS



S-02 SS

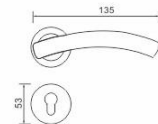

S-06 SS

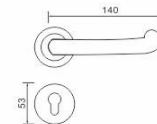

S-03 SS

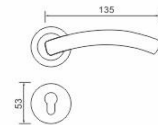

S-07 SS

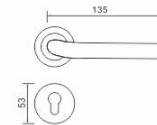

S-04 SS

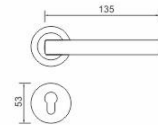

S-08 SS

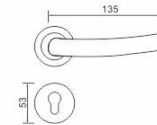



S-09 SS

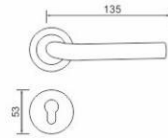

S-14 SS

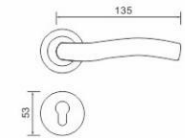

S-10 SS

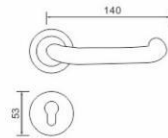

S-23 SS

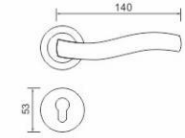

S-11 SS

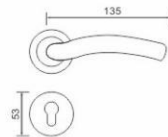

S-31 SS/PSS

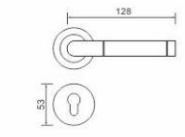

S-13 SS

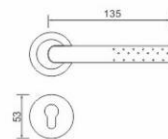

S-35 SS/PSS

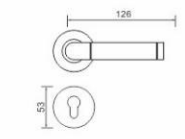



S-36 SS/PSS

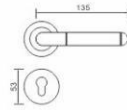

S-48 PSS

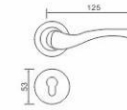

S-38 SS/PSS

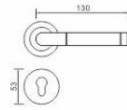

S-52 SS

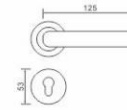

S-29 SS

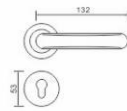

S-61 SS/PSS

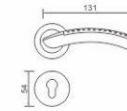

S-42 SS

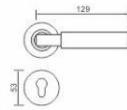

SF-15 SS

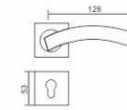

S-45 PSS

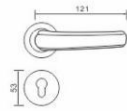

SF-16 SS

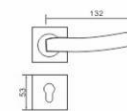



SF-17 SS

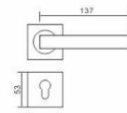

SF-18 SS

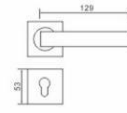

SF-19 SS

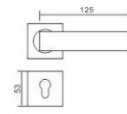

SF-21 SS

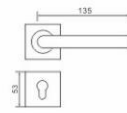

SF-58 SS

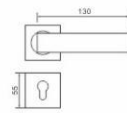

SA-01 SS

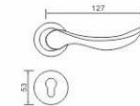

SA-02 SS

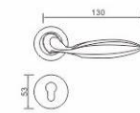

SA-03 SS

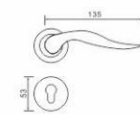

SA-04 SS

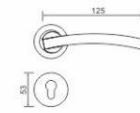

SA-05 SS

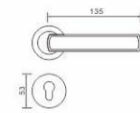









SA-36 SS

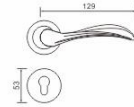

SA-37 SS

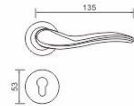

SA-38 SS

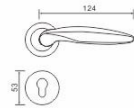

SA-39 SS

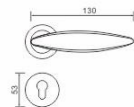

SA-40 SS

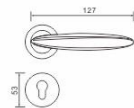

SA-41 SS

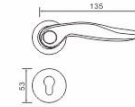

SA-42 SS

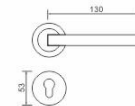

SA-43 SS

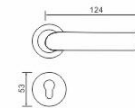

SA-44 SS

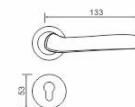

SA-45 SS

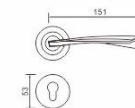



SA-46 SS

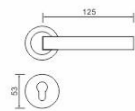

SA-47 SS

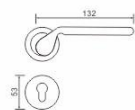

SA-48 SS

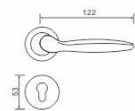

SA-49 SS

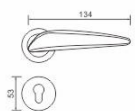

SA-50 SS

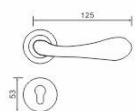

SA-51 SS

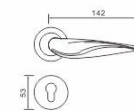

SA-52 SS

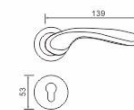

SA-53 SS

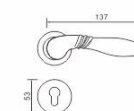

SA-54 SS

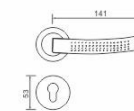

SA-55 SS

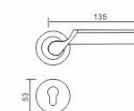



SA-57 PSS

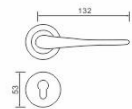

SA-59 PSS

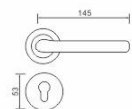

SA-60 PSS

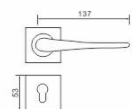

SA-100 SS

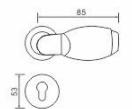

SA-113 SS

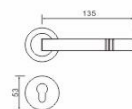

SA-120 SS/PSS

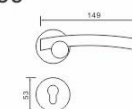

SA-122 SS

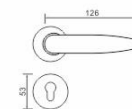

SA-124 SS

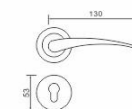

SA-130 SS/PSS

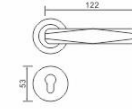

SA-131 SS/PSS

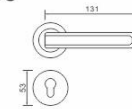



SA-132 SS

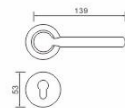

SA-140 SS/PSS

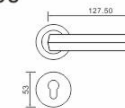

SA-133 SS

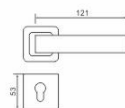

SA-141 SS

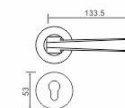

SA-134 SS

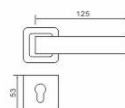

SA-142 SS

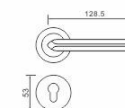

SA-136 SS/PSS

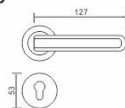

SA-143 SS

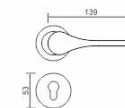

SA-137 SS/PSS

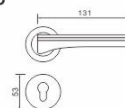

SA-144 SS/PSS

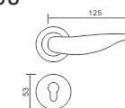



SA-145 SS

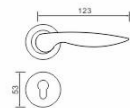

SA-146 SS

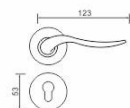

SA-147 SS

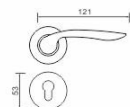

SA-148 SS

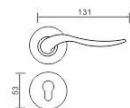

SA-149 SS

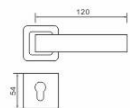

SA-150 SS

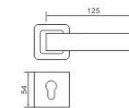

SA-151 SS

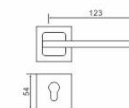

SA-152 SS

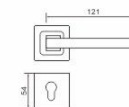

SA-153 SS

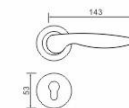

SA-154 SS

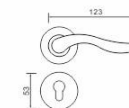



22H03 SS

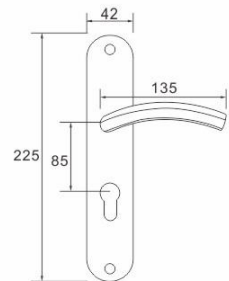

23H09 SS

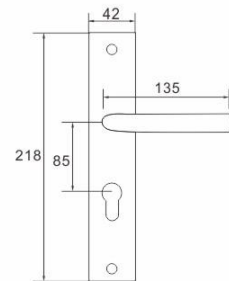

BK23H10 SS

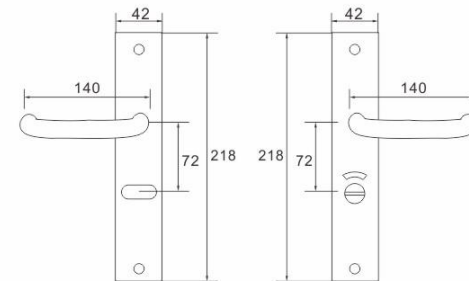



P22H36 SS

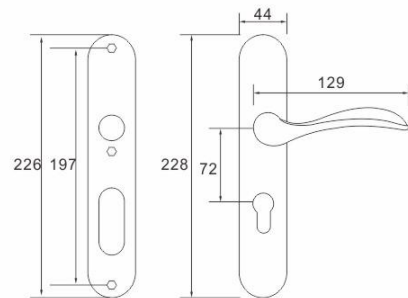

P22H38 SS

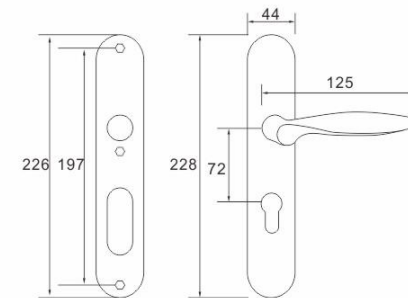



SB-100C-85 SS

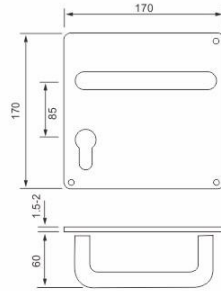

SB-100C-72 SS

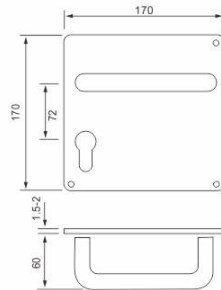

SE100 SS

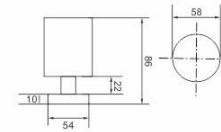

SE101 SS

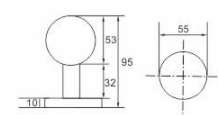

SE102 SS

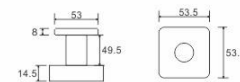

SE103 SS

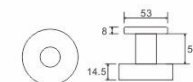



SC-100 SS

- Material: Stainless Steel Grade
- Finish: SS

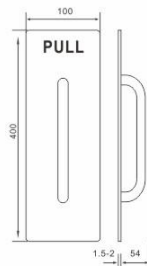

SC-201 SS

- Material: Stainless Steel Grade
- Finish: SS



SC-200 SS

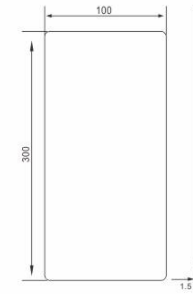

SC-201 SS

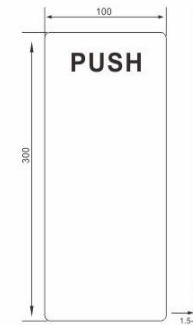

SC-202 SS

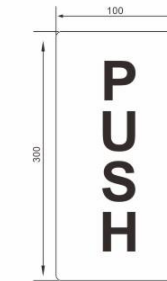



SW01 SS

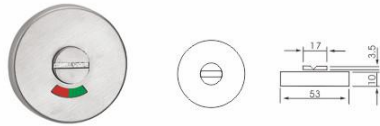

SW02 SS

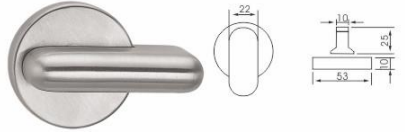

SW03 SS

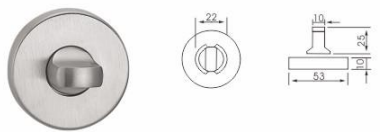

SW04 SS

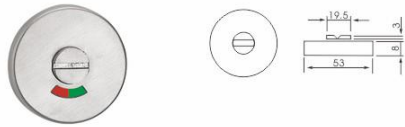

SN-01



SN-02

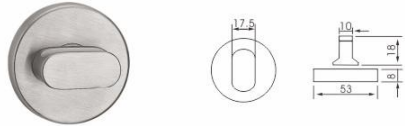

SN-04

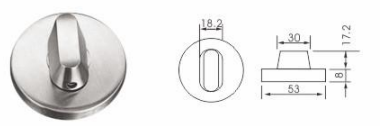

SN-05

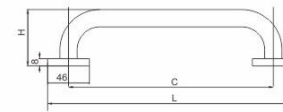
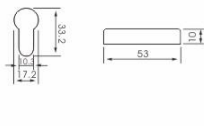
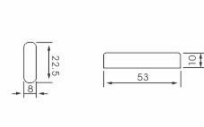
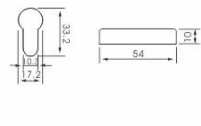
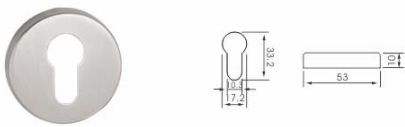

SC-101 SS

- Material: Stainless Steel Grade 201/304
- Finish: SS

| Art.No | Ø | C | L | H |
|------------|-------|-----|-----|----|
| SC-101/150 | 19/22 | 150 | 196 | 62 |
| SC-101/250 | 19/22 | 250 | 246 | 62 |
| SC-101/300 | 19/22 | 300 | 346 | 62 |



SC-104 SS

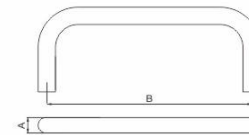

SC-104 SS

- Material: Stainless Steel Grade 201/304
- Finish: SS

| Art.No | A | B |
|--------|----|-----|
| SC-104 | 16 | 225 |
| SC-104 | 16 | 300 |
| SC-104 | 19 | 150 |
| SC-104 | 19 | 225 |
| SC-104 | 19 | 300 |
| SC-104 | 19 | 400 |
| SC-104 | 22 | 225 |
| SC-104 | 22 | 300 |
| SC-104 | 22 | 400 |
| SC-104 | 25 | 300 |
| SC-104 | 25 | 450 |
| SC-104 | 25 | 600 |
| SC-104 | 32 | 300 |
| SC-104 | 32 | 450 |
| SC-104 | 32 | 600 |
| SC-104 | 32 | 900 |



Double-side push/pull door handle for installation onto glass wooden&iron doors and glass swing doors. Modern design with a handle tube width of 30mm manufactured from 304 stainless steel with satin finish. Available in a range of lengths from 540mm to 2140mm. Screw to screw from 400mm to 2000mm.

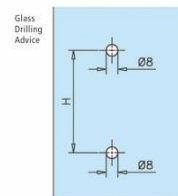
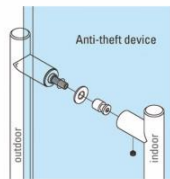

Item No. SC-103 SS

Finish : SS

Usage : Glass Wooden & Iron doors

Suitable for glass thickness of 8-12mm

- Material: Stainless Steel Grade 201/304
- Finish: SS

| Art.No | Ø | C | L | H |
|----------------|----|------|------|----|
| SC-103/30/400 | 30 | 400 | 540 | 45 |
| SC-103/30/500 | 30 | 500 | 640 | 45 |
| SC-103/30/600 | 30 | 600 | 740 | 45 |
| SC-103/30/800 | 30 | 800 | 940 | 45 |
| SC-103/30/900 | 30 | 900 | 1040 | 45 |
| SC-103/30/1100 | 30 | 1100 | 1240 | 45 |
| SC-103/30/1600 | 30 | 1600 | 1740 | 45 |
| SC-103/30/1800 | 30 | 1800 | 1940 | 45 |
| SC-103/30/2000 | 30 | 2000 | 2140 | 45 |



Double-side push/pull door handle for installation onto glass wooden&iron doors and glass swing doors. Modern design with a handle tube width of 25mm manufactured from 304 stainless steel with satin finish. Available in a range of lengths from 540mm to 2140mm. Screw to screw from 400mm to 2000mm.

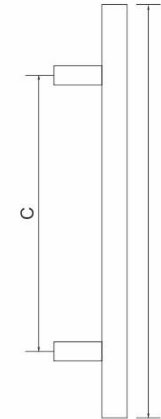

Item No. SC-105 SS

Finish : SS

Usage : Glass Wooden & Iron doors

Suitable for glass thickness of 8-12mm

- Material: Stainless Steel Grade 201/304
- Finish: SS

| Art.No | □ | C | L | H |
|----------------|----|------|------|----|
| SC-105/25/400 | 25 | 400 | 540 | 45 |
| SC-105/25/500 | 25 | 500 | 640 | 45 |
| SC-105/25/600 | 25 | 600 | 740 | 45 |
| SC-105/25/800 | 25 | 800 | 940 | 45 |
| SC-105/25/900 | 25 | 900 | 1040 | 45 |
| SC-105/25/1100 | 25 | 1100 | 1240 | 45 |
| SC-105/25/1600 | 25 | 1600 | 1740 | 45 |
| SC-105/25/1800 | 25 | 1800 | 1940 | 45 |
| SC-105/25/2000 | 25 | 2000 | 2140 | 45 |



P-001 SS

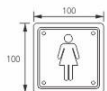

P-002 SS

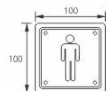

P-003 SS

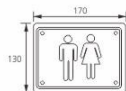

P-004 SS



P-005 SS



P-006 SS



P-007 SS



P-008 SS

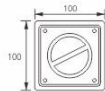

Note:
Size and pattern can be produced accordingly
Pattern: silk-screen & erosion are optional
Mounting options: visible fixing with screws;
Invisible fixing with double adhesive tape



NP-01 SS

- Material: Stainless Steel
- Finish: SS



NP-02 PB

- Material: Brass
- Finish: PB

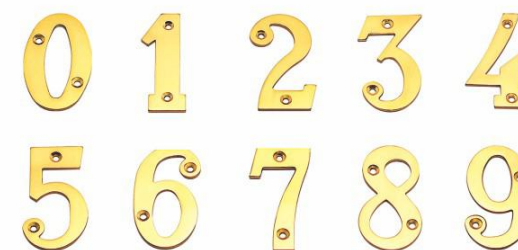

LP-01 PB

- Material: Brass
- Finish: PB





D3801-45 SS

Material: Stainless Steel
Finish: SS

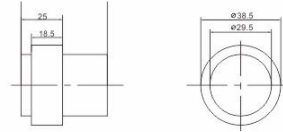

D3705 SN

Material: Zinc alloy
Finish: SN

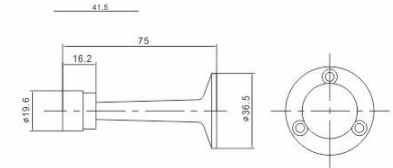

D3801-70 SS

Material: Stainless Steel
Finish: SS

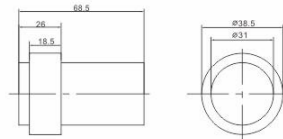

D3777 SS

Material: Stainless Steel
Finish: SS

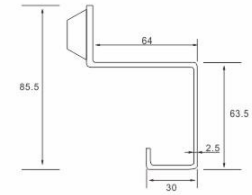

D3802 SS

Material: Stainless Steel/Brass
Finish: SS/SN

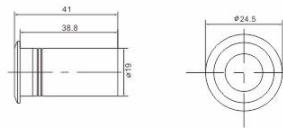

D3887 SC

Material: Zinc alloy
Finish: SC

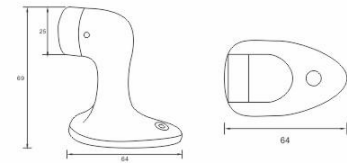

D3817 SS

Material: Stainless Steel
Finish: SS

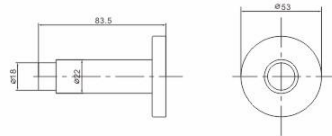

D3886 SC

Material: Zinc alloy
Finish: SC

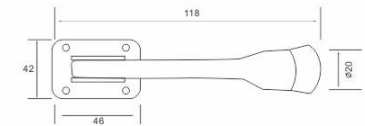

D3704 SN

Material: Zinc alloy/Stainless Steel
Finish: SN

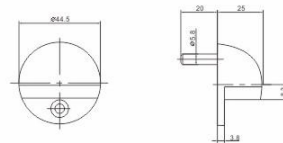

D3816 SN

Material: Zinc alloy
Finish: SN

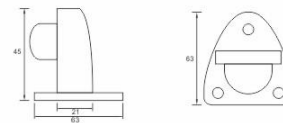

D3885 SN

Material: Zinc alloy
Finish: SN





D3850 SN

Material: Zinc alloy
Finish: SN

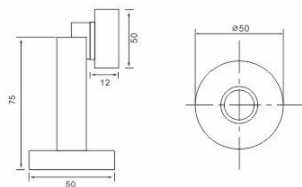

SB-301 SS

Material: Stainless Steel
Finish: SS

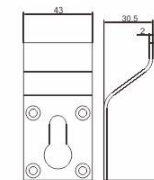

D3730 SN

Material: Aluminum alloy
Finish: SN

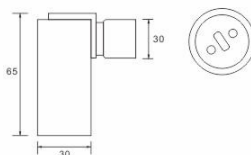

BP-05 SN

Material: Zinc alloy/Brass
Finish: SN

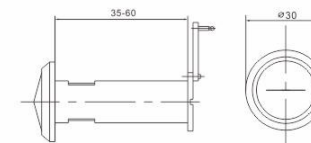

D3805 SN

Material: Zinc alloy
Finish: SN

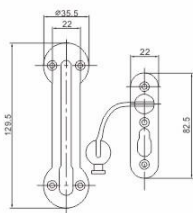

D3806 SN

Material: Zinc alloy
Finish: SN

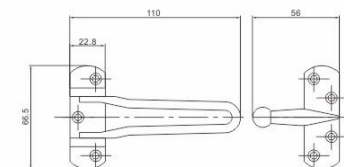

D3815 SN

Material: Zinc alloy
Finish: SN

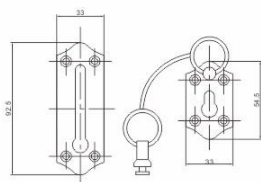

D3732

Material: Zinc alloy +
Stainless Steel chain
Finish: SS

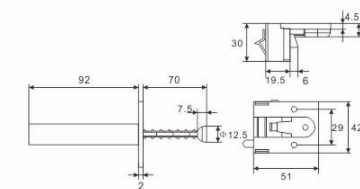

SB-201 SS

Material: Stainless Steel
Finish: SS

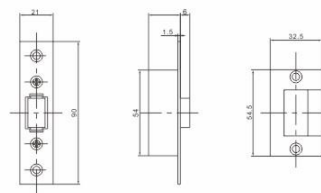

D3707 SN

Material: Zinc alloy
Finish: SN

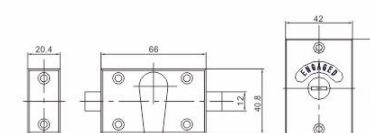

D3815 SN

Material: Zinc alloy
Finish: SN



YB-034 SN

Material: Zinc alloy/ brass/
Stainless Steel
Finish: SN

| Brass flush bolt | |
|------------------|------------------|
| Length | 6" ,8" ,10" ,12" |
| Width | 1" |

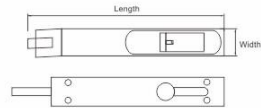

YB-037 SS

Material: Stainless Steel
Finish: SS

| Stainless Steel flush bolt | |
|----------------------------|--------|
| Length | 6" ,8" |
| Width | 1" |

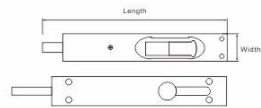

YB-054 SC

Material: Brass
Finish: SC

| Stainless Steel flush bolt | |
|----------------------------|-------|
| Length | 171.5 |
| Width | 25 |



D3830 MAC



D3831 MAB



D3832 RAB



D3833 MAB



D3834 SN/NP



D3835 SN/NP



D3836 GP



D3837 BN/GP



D3838 SN/CP





**BIG PULL HANDLE
SERIES**



H-1042 KOG

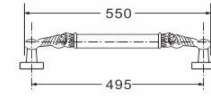

HA65-1043 KOG

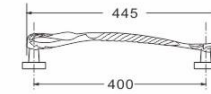

HA65-1044 KOG

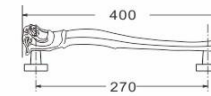

HA86-1045 GP

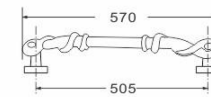



HA50-004 SN/CP



HA7-072 CP

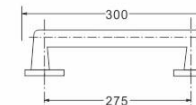

HA17-011 SN/CP



HA-101 SN/CP

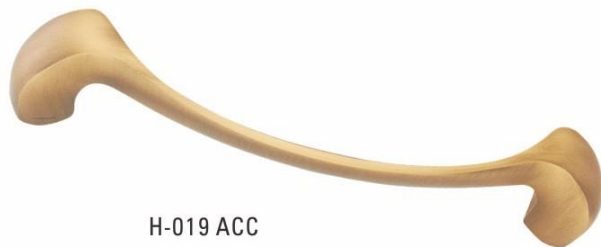
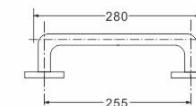

H-019 ACC

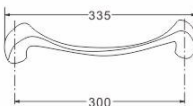

HA-111 SN/CP

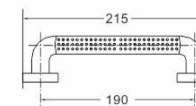

HA7-056 SN

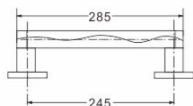

HA-116 SN/CP

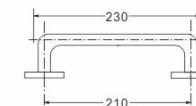



H-121PVD

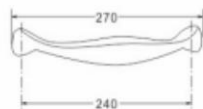

H-123 PVD/CP



H-124 MSN/CP

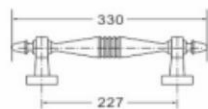

HA-125 MSN/CP



HA7-127 MAB



HA31-130 MAB

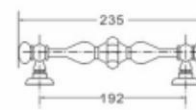

HA-144 SN/CP

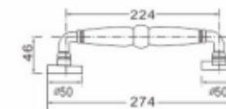

HA10-913 MAB

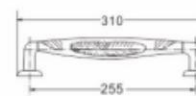



HA10-165 RSB

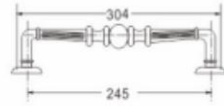

HA7-186 CP

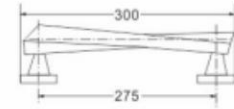

HA7-170 CP/BLACK

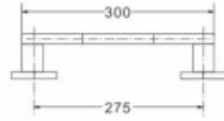

HA7-187 SN/CP

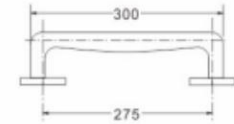

HA2-173A MAB

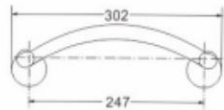

HA7-188 MAB

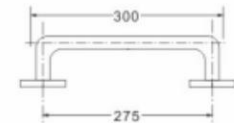

HA2-174 MCOF

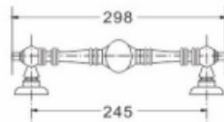

HA33-201 MAB

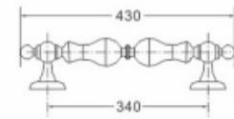



HA33-202 PVD

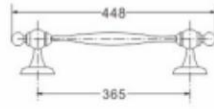

HA10-221 ACC

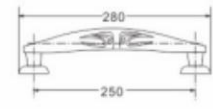

HA-203 SN/CP

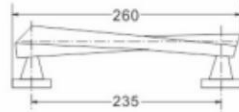

HA-239 SN/CP



HA-204 SN

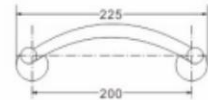

HA-255 SN/CP

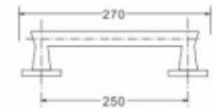

HA-205 SN

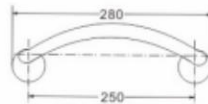

HA7-283 SN/CP

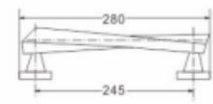



HA10-301 MAB

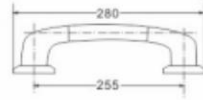

HA-335 MAB

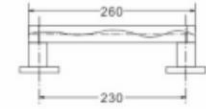

HA10-304 MAB

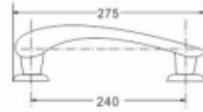

HA17-336 SN/CP



HA10-310 MAB

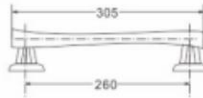

HA7-339 SN/CP



HA-334 SN/CP



H-339L PVD





HA7-365 SN/CP



HA21-419 SN/CP

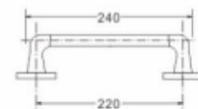

HA7-366 SN/CP

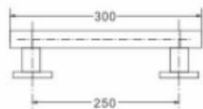

HA-438 SN/CP

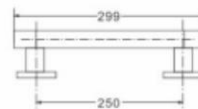

HA41-378 SN/CP



HA-443 SN/CP

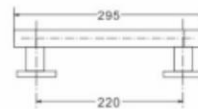

HA-400 SN/CP



HA41-507 SN/CP

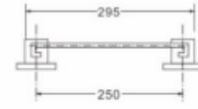



HA17-516 MCOF

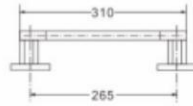

HA50-586 RSG

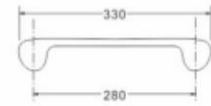

HA65-574 SN



HA15-722 MAB

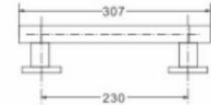

H66-576 RSG

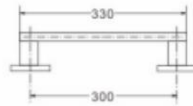

HA-802 SN/CP



HA7-578 CP



HA10-818 MAB

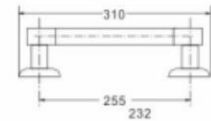



HA-826 SN/CP



HA-997 MAB

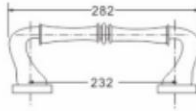

H-1018L RSG

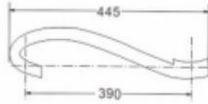

H-1018S SN

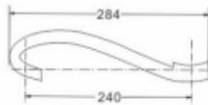

H-1033-A PVD

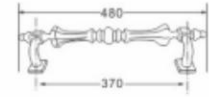

H-1036-A PVD

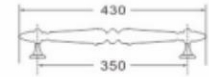

HA10-1038 PVD

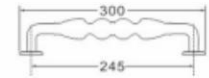

H-1046 MCOF

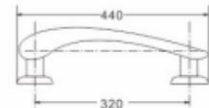

CE

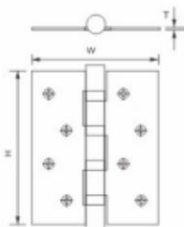

SS-01

BEARING HINGE
SURFACE TREATMENT:
SS/PSS/AB/AC/PVD
MATERIAL:
Stainless steel (304/201)
AVAILABLE FOR:
All kinds of wooden gate door, room door
FEATURES:
Switching flexibility, No noise, Long life

| Dimension(HxWxT) | Bearing |
|------------------|---------|
| 4"x3"x2.0mm | 4BB/2BB |
| 4"x3"x2.5mm | 4BB/2BB |
| 4"x3"x3.0mm | 4BB/2BB |
| 4"x3"x3.5mm | 4BB/2BB |

CE

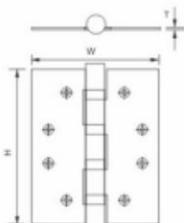

SS-02

BEARING HINGE
SURFACE TREATMENT:
SS/PSS/AB/AC/PVD
MATERIAL:
Stainless steel (304/201)
AVAILABLE FOR:
All kinds of wooden gate door, room door
FEATURES:
Switching flexibility, No noise, Long life

| Dimension(HxWxT) | Bearing |
|------------------|---------|
| 4"x3.5"x2.5mm | 4BB/2BB |
| 4"x3.5"x3.0mm | 4BB/2BB |
| 4"x3.5"x3.5mm | 4BB/2BB |

CE

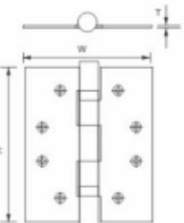

SS-03

BEARING HINGE
SURFACE TREATMENT:
SS/PSS/AB/AC/PVD
MATERIAL:
Stainless steel (304/201)
AVAILABLE FOR:
All kinds of wooden gate door, room door
FEATURES:
Switching flexibility, No noise, Long life

| Dimension(HxWxT) | Bearing |
|------------------|---------|
| 4"x4"x2.5mm | 4BB/2BB |
| 4"x4"x3.0mm | 4BB/2BB |
| 4"x4"x3.5mm | 4BB/2BB |

UL
LISTED

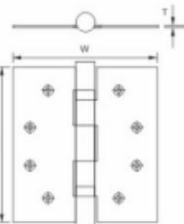

SS-04

BEARING HINGE
SURFACE TREATMENT:
SS/PSS/AB/AC/PVD
MATERIAL:
Stainless steel (304/201)
AVAILABLE FOR:
All kinds of wooden gate door, room door, steel door
FEATURES:
Switching flexibility, No noise, Long life
supplied with:
machine screws, wooden screws

| Dimension(HxWxT) | Bearing |
|------------------|---------|
| 4.5"x4"x3.0mm | 4BB/2BB |
| 4.5"x4"x3.5mm | 4BB/2BB |
| 4.5"x4.5"x3.0mm | 4BB/2BB |
| 4.5"x4.5"x3.5mm | 4BB/2BB |

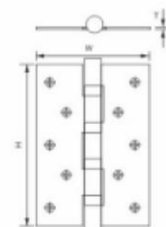

SS-05

BEARING HINGE
SURFACE TREATMENT:
SS/PSS/AB/AC/PVD
MATERIAL:
Stainless steel (304/201)
AVAILABLE FOR:
All kinds of wooden gate door, room door
FEATURES:
Switching flexibility, No noise, Long life

| Dimension(HxWxT) | Bearing |
|------------------|---------|
| 6"x4"x3.5mm | 4BB |
| 6"x4"x4mm | 4BB |

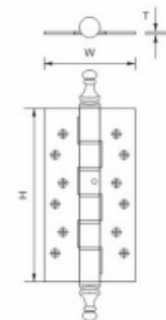

SS-12 PVD

BEARING HINGE
SURFACE TREATMENT:
SS/PSS/AB/AC/PVD
MATERIAL:
Stainless steel (304/201)
AVAILABLE FOR:
All kinds of wooden gate door, room door
FEATURES:
Switching flexibility, No noise, Long life

| Dimension(HxWxT) | Bearing |
|------------------|---------|
| 6.5"x3.5"x4mm | 4BB |

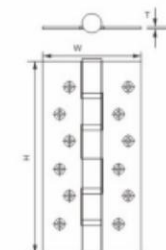

SS-13 SS

BEARING HINGE
SURFACE TREATMENT:
SS/PSS/AB/AC/PVD
MATERIAL:
Stainless steel (304/201)
AVAILABLE FOR:
All kinds of wooden gate door, room door
FEATURES:
Switching flexibility, No noise, Long life

| Dimension(HxWxT) | Bearing |
|------------------|---------|
| 8"x4"x3.0mm | 4BB |
| 8"x4"x3.5mm | 4BB |
| 8"x4"x4.0mm | 4BB |

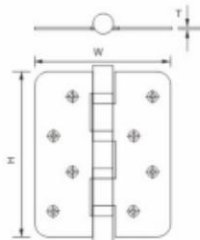

SS-01R

ROUND CORNER HINGE
SURFACE TREATMENT:
SS/PSS/AB/AC/PVD
MATERIAL:
Stainless steel (304/201)
AVAILABLE FOR:
All kinds of wooden gate door, room door
FEATURES:
Switching flexibility, No noise, Long life

| Dimension(HxWxT) | Bearing |
|------------------|---------|
| 4"x3"x2.0mm | 4BB/2BB |
| 4"x3"x2.5mm | 4BB/2BB |
| 4"x3"x3.0mm | 4BB/2BB |
| 4"x3"x3.5mm | 4BB/2BB |

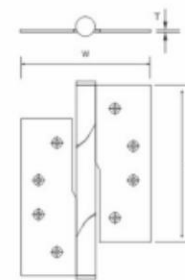

SS-09

RISING HINGE
SURFACE TREATMENT:
SS/PSS/AB/AC/PVD
MATERIAL:
Stainless steel (304/201)
AVAILABLE FOR:
All kinds of wooden gate door, room door
FEATURES:
Switching flexibility, No noise, Long life

| Dimension(HxWxT) | Bearing |
|------------------|---------|
| 4"x3"x2.0mm | |
| 4"x3"x3.0mm | |
| 3"x2.5"x2.0mm | |

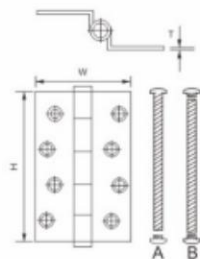

SS-07

OFFSET HINGE
SURFACE TREATMENT:
SS/PSS/AB/AC/PVD
MATERIAL:
Stainless steel (304/201)
AVAILABLE FOR:
All kinds of wooden gate door, room door
FEATURES:
Switching flexibility, No noise, Long life

| Dimension(HxWxT) | Bearing |
|------------------|---------|
| 4"x3"x3.0mm | 2BB |
| 4"x3.5"x3.0mm | 2BB |

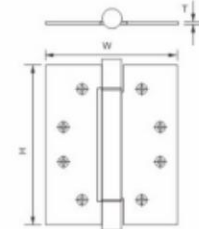

SS-10

SINGLE ACTION HINGE
SURFACE TREATMENT:
SS/PSS/AB/AC/PVD
MATERIAL:
Stainless steel (304/201)
AVAILABLE FOR:
All kinds of wooden gate door, room door
FEATURES:
Switching flexibility, No noise, Long life

| Dimension(HxWxT) | Bearing |
|------------------|---------|
| 4"x3"x2.5mm | |
| 4"x3"x3.0mm | |
| 4"x4"x3.0mm | |

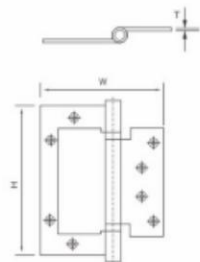

SS-08

ROUND CORNER FLUSH HINGE
SURFACE TREATMENT:
SS/PSS/AB/AC/PVD
MATERIAL:
Stainless steel (304/201)
AVAILABLE FOR:
All kinds of wooden gate door, room door
FEATURES:
Switching flexibility, No noise, Long life

| Dimension(HxWxT) | Bearing |
|------------------|---------|
| 100x75x2.0mm | 2BB |
| 100x78x2.5mm | 2BB |
| 100x78x3.0mm | 2BB |

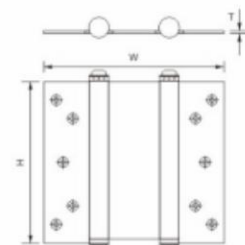

SS-11

DOUBLE ACTION HINGE
SURFACE TREATMENT:
SS/PSS/AB/AC/PVD
MATERIAL:
Stainless steel (304/201)
AVAILABLE FOR:
All kinds of wooden gate door, room door
FEATURES:
Switching flexibility, No noise, Long life

| Dimension(HxWxT) | Bearing |
|------------------|---------|
| 4" | |
| 5" | |
| 6" | |

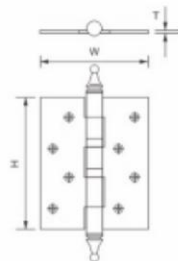
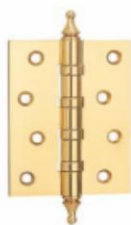

BH-01

SRIFACE TREATMENT:
SN/CP/AB/AC/PB
MATERIAL:
Brass
AVAILABLE FOR:
All kinds of wooden gate door, room door
FEATURES:
Switching flexibility, No noise, Long life

| Dimension(HxWxT) | Bearing |
|------------------|---------|
| 4"x3"x2.5mm | 4BB/2BB |
| 4"x3"x3.0mm | 4BB/2BB |
| 4"x2"x4.0mm | 4BB/2BB |
| 4"x3.5"x3.0mm | 4BB/2BB |

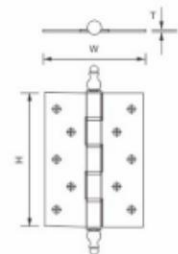

BH-02

SRIFACE TREATMENT:
SN/CP/AB/AC/PB
MATERIAL:
Brass
AVAILABLE FOR:
All kinds of wooden gate door, room door
FEATURES:
Switching flexibility, No noise, Long life

| Dimension(HxWxT) | Bearing |
|------------------|---------|
| 6"x4"x4mm | 4BB |

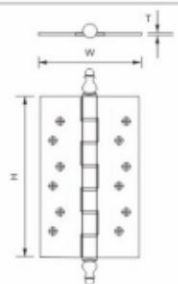

BH-03

SRIFACE TREATMENT:
SN/CP/AB/AC/PB
MATERIAL:
Brass
AVAILABLE FOR:
All kinds of wooden gate door, room door
FEATURES:
Switching flexibility, No noise, Long life

| Dimension(HxWxT) | Bearing |
|------------------|---------|
| 8"x4"x4.0mm | 6BB |
| 8"x5"x4.0mm | 6BB |

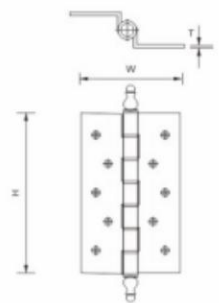

BH-04

SRIFACE TREATMENT:
SN/CP/AB/AC/PB
MATERIAL:
Brass
AVAILABLE FOR:
All kinds of wooden gate door, room door
FEATURES:
Switching flexibility, No noise, Long life

| Dimension(HxWxT) | Bearing |
|------------------|---------|
| 3"x2.5"x2.5mm | 2BB |
| 4"x3"x3.0mm | 2BB/4BB |
| 4"x3.5"x4.0mm | 2BB/4BB |
| 5"x3.5"x4.0mm | 2BB/4BB |
| 6"x4"x4.0mm | 4BB |
| 6"x4"x4.5mm | 4BB |
| 8"x4"x4.0mm | 4BB |
| 8"x4"x4.5mm | 4BB |



ACH 001 (Left) ACH 002 (Right)

Material: Zinc alloy
Finish: SC, SN, CP, NP, AB, AC, etc.
Area of application: For wooden frames, for steel frames, for aluminum frames, etc.
Installation: Door weight : ≤60 kg with 3 door hinges
Opening angle: ≤180°
Door width: ≤1000mm
Door thickness: ≥40mm
Door height: ≥2100mm with 4 door hinges
Size: 110mm
Adjustment facility: Continuously 3D adjustable
Height ±1.5 mm, side and closing pressure ±1 mm
Mounting: Suitable for DIN left hand, DIN right hand

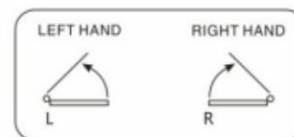
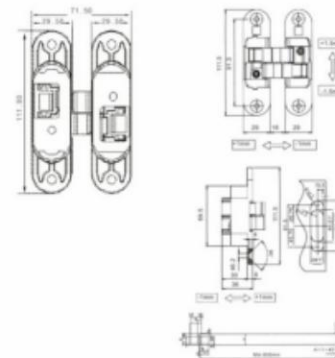

ACH007

Material: S5304
Finish: SC, SN, CP, NP, AB, AC, etc.
Area of application: For wooden frames, for steel frames, for aluminum frames, etc.
Installation: Door weight : ≤60 kg with single door hinges
Opening angle: ≤180°
Door width: ≤1000mm
Door thickness: ≥40mm
Size: 160mm
Adjustment facility: Continuously 3D adjustable
Height and side ±3 mm, closing pressure ±1 mm
Mounting: Suitable for DIN left hand and DIN right hand

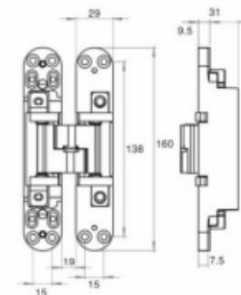



| Dimension (mm) | Zinc Alloy Shell Stainless Steel Core Concealed Hinge Parameter | | | | | | | | | | |
|----------------------|-----------------------------------------------------------------|--------------------------------|--------|--------|--------|--------|--------|--------|--------|--------------------------------|--------|
| | ZCH001 | ZCH002 | ZCH003 | ZCH004 | ZCH005 | ZCH006 | ZCH007 | ZCH008 | ZCH009 | ZCH010 | ZCH011 |
| | 34X140 | 28X118 | 25X118 | 19X95 | 16X70 | 13X60 | 13X45 | 28X118 | 28X118 | 28X118 | 19X118 |
| A | 34 | 28 | 25 | 19 | 16 | 13 | 13 | 28 | 25 | 28 | 19 |
| B | 139.5 | 117.5 | 117.5 | 95 | 70 | 60 | 45 | 117.5 | 117.5 | 117.5 | 95 |
| C | 27.5 | 22 | 18 | 13 | 11 | 9 | 9 | 25 | 18 | 22 | 13 |
| D | 74.5 | 61.5 | 64 | 51.2 | 34 | 30 | 19 | 61.5 | 64 | 61.5 | 51.2 |
| E | 1.6 | 1.4 | 1.6 | 1.2 | 0.8 | 0.8 | 0.8 | 1.4 | 1.6 | 1.4 | 1.2 |
| F | 51 | 41 | 36 | 27 | 22.5 | 18 | 18 | 44 | 36 | 41 | 27 |
| G | 11.5 | 9.5 | 11 | 9 | 7 | 6 | 5 | 12 | 11.5 | 9.5 | 9 |
| H | outer hole 113.5 inner hole 102.5 | outer hole 93 outer hole 87 | 90 | 73 | 51 | 47 | 30.5 | 90 | 90 | outer hole 93 inner hole 87 | 73 |
| Door thickness | 50mm | 40mm | 35mm | 30mm | 25mm | 20mm | 20mm | 40mm | 35mm | 40mm | 30mm |
| Each weight g/pc | 1400g | 785g | 650g | 310g | 160g | 85g | 55g | 800g | 630g | 1090g | 276g |
| Bearing weight kg/pc | 50kg | 40kg | 30kg | 25kg | 15kg | 10kg | 5kg | 25kg | 30kg | 40kg | 25kg |

Installation: 3pcs for a door, it depends on door thick, weight, and actual situation.

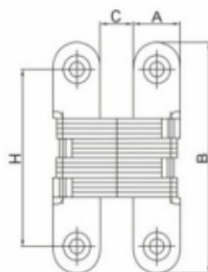

| Dimension (mm) | Full Stainless Steel Concealed Hinge Parameter | | | | | | | | | |
|----------------------|------------------------------------------------|--------------------------------|--------|--------|--------|--------------------------------|--------|--------|--------------------------------|---------|
| | SCH001 | SCH002 | SCH003 | SCH004 | SCH005 | SCH006 | SCH007 | SCH008 | SCH002B | SCH003B |
| | 34X140 | 28X118 | 25X118 | 19X95 | 16X70 | 28X118 | 25X118 | 19X95 | 28X118 | 25X118 |
| A | 34 | 28 | 25 | 19 | 16 | 28 | 25 | 19 | 28 | 25 |
| B | 139.5 | 118 | 118 | 95 | 70 | 118 | 118 | 95 | 118 | 118 |
| C | 27.5 | 22 | 18 | 13 | 11 | 22 | 18 | 13 | 22 | 18 |
| D | 74.5 | 61.5 | 65.3 | 52.2 | 34 | 61.5 | 65.3 | 52.5 | 61.5 | 65.3 |
| E | 1.6 | 1.4 | 1 | 1.2 | 0.8 | 1.4 | 1 | 1.2 | 1.4 | 1 |
| F | 51 | 41 | 36.5 | 27 | 22.5 | 41 | 36.5 | 27 | 41 | 36.5 |
| G | 11.5 | 9.5 | 11.3 | 9 | 7.4 | 9.5 | 11.3 | 9 | 9.5 | 11.3 |
| H | outer hole 113.5 inner hole 102.5 | outer hole 93 inner hole 88 | 90.5 | 73 | 51 | outer hole 93 inner hole 88 | 90.5 | 73 | outer hole 93 inner hole 88 | 90.5 |
| Door thickness | 50mm | 40mm | 35mm | 30mm | 25mm | 40mm | 35mm | 30mm | 40mm | 35mm |
| Each weight g/pc | 1400g | 885g | 655g | 375g | 160g | 1140g | 635g | 341g | 885g | 665g |
| Bearing weight kg/pc | 50kg | 40kg | 30kg | 25kg | 15kg | 40kg | 30kg | 25kg | 40kg | 30kg |

Installation: 3pcs for a door, it depends on door thick, weight, and actual situation.

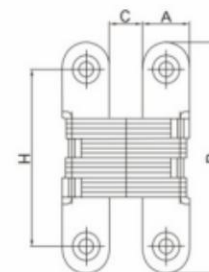



904 Φ 9x30 M5.5x25



904 Φ 11x37 M5.5x25



904 Φ 13x38 M8x37



907 Φ 12x42 M5.5x25



907 Φ 14x48 M8x35



907 Φ 16x45 M8.5x45



904 Φ 13x43 M8x37



904 Φ 14x36 M8x38



904 Φ 16x52 M8.5x45



907 Φ 16x60 M8.5x45



907-3S Φ 14x86 M8x40



907-5S Φ 14x74



905 Φ 9x65 M5.5x25



905 Φ 11x75 M5.5x25



905 Φ 13x87 M8x35



908 Φ 13x58 M8x45



908-K Φ 13x62 M8x50



908-K Φ 15x80



905 Φ 14x90 M8x37



905 Φ 16x95 M8.5x45



905 Φ 15x120 M8x45



908 Φ 15x80 M8x50



908T Φ 15x80 M8x50



908T-K Φ 15x80



909T/22 Φ 14x82 M8x40



909T/22 Φ 15x82 M8x45



909T/22 Φ 16x82 M8x45



909C-P Φ 14x48



909C-P Φ 15x48

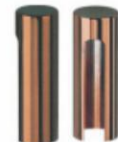

909C-P Φ 16x48



909C-P Φ 20x60



909C-Y Φ 14x50



911-2S Φ 13x53 M8x35



911-2S Φ 13x53 M8x40



911-2S Φ 13x68 M8x40



909C-Y Φ 15x50



909C-Y Φ 16x50



909C-Y Φ 20x65



909C-H(p) Φ 14x75



909C-H(b) Φ 14x65



911-3S Φ 15x83 M8x40



911-3S Φ 15x83 M8x50



911-2S Φ 15x86 M8x43



911-2S Φ 15x86 M8x50



911-5S Φ 15x83



911C-P(p)-K Φ 15x86



Jig Kit E



Jig Kit D



Installing
Screw pin

Spanner

Drill

Ring

INSTALLATION JIG AND METHOD



KC1001-3 AD/SL

KC1001 series door closers adopt the alloy aluminium die casting crust body, is provided with beautiful and lightness appearance, reasonable construction and good performance, belongs to High economical efficiency products. you can install them by vertical or parallel or sliding rail and so on. and the matching cover casing can be chosen. It is preferred products in the fire-resistance and anti-theft door fields. You can choose different luxurious covers according to your decoration.

| Product model | Main parameter | | | | | Applicable door weight (kgs) |
|----------------|-------------------|------|----|---------------------|----|------------------------------|
| | Overall dimension | | | Mounthole dimension | | |
| | A | B | E | C | D | |
| KC1000-1 AW/AD | 148 | 37.5 | 57 | 132 | 19 | 15-30 |
| KC1000-2 AW/AD | 148 | 37.5 | 57 | 132 | 19 | 25-45 |
| KC1001-2 AW/AD | 180 | 42 | 63 | 165 | 19 | 25-45 |
| KC1001-3 AD | 180 | 42 | 63 | 165 | 19 | 40-65 |
| KC1002-3 AW/AD | 186 | 44.5 | 67 | 168 | 19 | 40-65 |
| KC1002-4 AW | 186 | 44.5 | 67 | 168 | 19 | 60-85 |

Introduction for Performance

Closing speed can be adjusted independently.
Latching speed can be adjusted independently.
AD type door closers can keep stopping state exceed 85 degree.

AD: Locating Device.
AW: Non-locating Device, With Closing, Latching Function

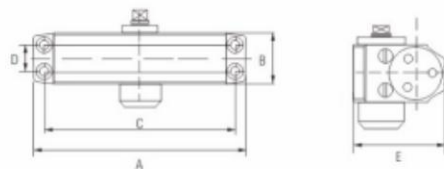

KC1005-5 BW/SL

KC1005 series door closer body is made of the alloy aluminium material die casting, they are simple and graceful in appearance, reasonable in construction, perfect in performance, complete patterns, measure series, used widely is security defend, commercial and domestic doors. You can install them by vertical or parallel or sliding rail and so on. And you can choose different luxurious covers according to your decoration.

| Product model | Main parameter | | | | | Applicable door weight |
|----------------|-------------------|------|----|---------------------|----|------------------------|
| | Overall dimension | | | Mounthole dimension | | |
| | A | B | E | C | D | |
| KC1029-2 AW/AD | 148 | 37.5 | 57 | 132 | 19 | 25-45 |
| KC1030-3 AW/AD | 182 | 42 | 63 | 165 | 19 | 40-65 |
| KC1032-4 AW/BW | 227 | 46 | 72 | 208 | 19 | 60-85 |
| KC1005-5 BW | 248 | 46 | 72 | 230 | 19 | 80-120 |
| KC1005-36 BW | 248 | 46 | 72 | 230 | 19 | 40-150 |

Introduction for Performance

Closing speed can be adjusted independently.
Latching speed can be adjusted independently.
AD type door closers can keep stopping state exceed 85 degree.
KC1005-5 BW have back check functions and adjustable speed.
KC1005-36 BW are provided with back check and closing force adjustment fuctions.

BW: Back Check Function
AW: Non-locating Device, With Closing, Latching Function

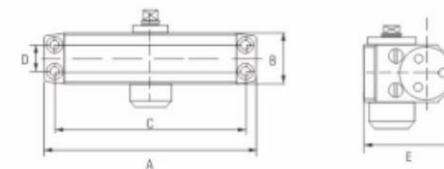



KC1006-3 AW/SL

KC1006 series door closer adopt the alloy aluminium die casting crust body, KC1006 series adopt the aluminium profiles crust body, is provided with beautiful and graceful appearance, reasonable construction reliable and secure performance; This is a high quality concealed door closer, which installed on slide rail style inside door or top jamb.

| Product model | Main parameter | | | | | |
|---------------|-------------------|----|------|---------------------|----|------------------------------|
| | Overall dimension | | | Mounthole dimension | | Applicable door weight (kgs) |
| | A | B | E | C | D | |
| KC1006-2 AW | 230 | 63 | 32.5 | 260 | 20 | 25-45 |
| KC1006-3 AW | 230 | 63 | 32.5 | 260 | 20 | 40-65 |
| KC1006-4 AW | 230 | 63 | 32.5 | 260 | 20 | 60-85 |
| KC1106-2 AW | 230 | 63 | 32.5 | 260 | 20 | 25-45 |
| KC1106-3 AW | 230 | 63 | 32.5 | 260 | 20 | 40-65 |
| KC1106-4 AW | 230 | 63 | 32.5 | 260 | 20 | 60-85 |

Introduction for Performance

Closing speed can be adjusted independently.
Latching speed can be adjusted independently.
Slide rail has hold open door device and the angle of hold open door can be adjustable anywhere.

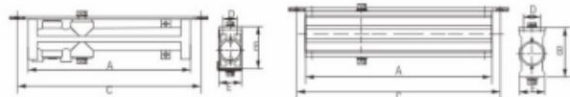

AD: Optional (with Rail)
AW: Non-latching Device, With Closing, Latching Function

KC1148-24 CW/SL

This series can adopt the high grade aluminum profiles crust body, or adopt the high grade alloy aluminum die casting crust body. This series have beautiful and generous appearance, stronger ornamental effect, advanced construction and stable performance. Convenient install and operation. It is one of products welcomed by customers. You can install them by vertical or parallel or sliding rail and so on.

| Product model | Main parameter | | | | | |
|----------------|-------------------|----|------|---------------------|----|------------------------------|
| | Overall dimension | | | Mounthole dimension | | Applicable door weight (kgs) |
| | A | B | E | C | D | |
| KC102B-2 AW/AD | 177 | 51 | 38 | 60 | 38 | 25-45 |
| KC102B-3 AW/AD | 177 | 51 | 38 | 60 | 38 | 40-65 |
| KC112B-2 AW/AD | 177 | 51 | 38 | 60 | 38 | 25-45 |
| KC112B-3 AW/AD | 177 | 51 | 38 | 60 | 38 | 40-65 |
| KC113B-3 AW | 207 | 60 | 43.5 | 160 | 46 | 40-65 |
| KC114B-24 CW | 227 | 60 | 43.5 | 160 | 46 | 25-85 |
| KC115B-36 CW | 287 | 60 | 43.5 | 160 | 46 | 40-150 |

Introduction for Performance

Closing speed can be adjusted independently.
Latching speed can be adjusted independently.
AD type door closers can keep stopping state exceed opening the angle 85 degree.
KC1148-24 BW have back check and delay functions and speed can separately regulate.
KC1148-24 CW and KC1158-36 CW door closers are provided with back check delay and closing force adjustment functions.

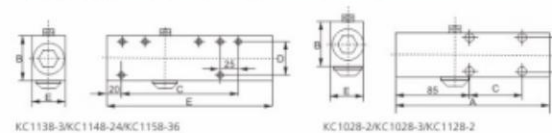

AD: Latching Device.
AW: Non-latching Device, With Closing, Latching Function
CW: With Closing, Latching, Back Check, Time Delay Function



KD-F3000-A



KD-F3200-A SS

KD-F3000-A UL Panic Exit Device, Rim Type, single leaf door

Features of the KD-F3000-A Rim Type Half length Panic Exit Device
Features of the the KD-F3000-A Rim Type Full length Panic Exit Device

- Type: Rim type, Half length or length
- Material: Heavy gauge steel or stainless steel
- Length: 1045MM as a standard, could be customized
- Color: Silver painted or stainless steel as a standard, could be customized
- Accommodates wood and metal doors with thru bolts standard
- Apply to door for fire protection, some ventilation.
- Apply to single leaf door
- Could be match with outside access device like cylinder, trim and lever
- Conforming to ANSI/BHMA standard A 156.3 Grade 1.
- Open by handspike inside, and by key outside.
- Endurance test, over 500,000 times still keep good performance.
- Surface mounted for ease of installation.
- Non fire rated devices come standard with hex key dogging.



KD-F3200-A Fire Rated Exit Device, Rim Type, single leaf door

Features of the the KD-F3200-A Rim Type Half length Panic Exit Device
Features of the the KD-F3200-A Rim Type Full length Panic Exit Device

- Type: Rim type, Half length
- Material: Heavy gauge steel or 304 stainless steel
- Length: 1045MM as a standard, could be customized
- Color: Alum as a standard, could be customized
- Accommodates wood and metal doors with thru bolts standard
- Match with outside access device like cylinder, trim and lever
- Apply to door for fire protection, some ventilation.
- Apply to single leaf door
- Conforming to U.L.10C and ANSI/BHMA A156.3-(2008)Grade 1.
- U.L./U.L.C listed for "Fire exit hardware" labeled for rating up to and including 3 hours.
- Endurance test, over 500,000 times still keep good performance.
- Surface mounted for ease of installation.



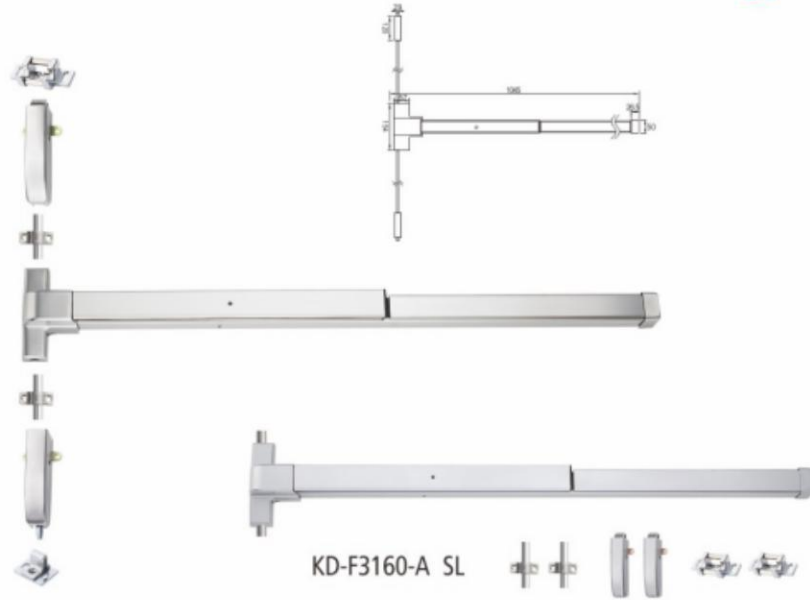

KD-F3160-A SL

KD-F3160-A SS

KD-F3160 UL Panic Exit Device-Double door with two vertical rod type exit devices.

Features of the KD-F3160-A/KD-F3560-A Rim Type Half length Panic Exit Device
Features of the the KD-F3160-A/KD-F3560-A Rim Type Full length Panic Exit Device

- Type:Rim type,Half length or Full length
- Material:Heavy gauge steel or stainless steel
- Length:1045MM as a standard,could be customized
- Color: Sliver painted or stainless steel as a standard,could be customized
- Accommodates wood and metal doors with thru bolts standard
- Match with outside access device like cylinder,trim and lever
- Automatic top and bottom laches miantaining the bolt drawn in when the door is open
- Conforming to ANSI/BHMA standard A 156.3 Grade 1.
- Endurance test,over 500,000 times still keep good performance.
- Surface mounted for ease of installtion.
- DOOR HEIGHT:2100MM as standard,other door height can be customized
- LATCH:No latch required in panic exit device,2-point function by vertical rod
- SCREW:Screw bolt,metal screw and wood scerw
- Non fire rated devices come standard with hex key dogging.
- Dogging:Allen key



KD-F3300-A SS

KD-F3300-A Fire Rated Exit Device,Rim Type,single leaf door

Features of the the KD-F3300-A Rim Type Half length Panic Exit Device
Features of the the KD-F3300-A Rim Type Full length Panic Exit Device

- Type:Rim type,Half length or Full length
- Material:Heavy gauge steel or 304 stainless steel
- Length:1045MM as a standard,could be customized
- Color: Silver painted or stainless steel as a standard,could be customized
- Accommodates wood and metal doors with thru bolts standard
- Match with outside access device like cylinder,trim and lever
- Apply to door for fire protection,somke ventilation.
- Apply to single leaf door
- Conforming to U.L.10C and ANSI/BHMA A156.3-(2008)Grade 1.
- U.L./U.L.C listed for "Fire exit hardware" labeled for rating up to and including 3 hours.
- Endurance test,over 500,000 times still keep good performance.
- Surface mounted for ease of installtion.





KD-F3400-A SS



**Fire rated exit device, rim type,
Single leaf door & double leaf door**

- Type: Rim type, Half length
- Material: Extruded alum body, 304 stainless steel push plate
- Length: 800MM as a standard, could be customized
- Color: Alum as a standard, could be customized
- Accommodates wood and metal doors with thru bolts standard
- Match with outside access device like cylinder, trim and lever
- Apply to door for fire protection, smoke ventilation.
- Apply to single leaf door, double leaf door
- Conforming to U.L.10C and ANSI/BHMA A156.3-(2008) Grade 1.
- U.L./U.L.C listed for "Fire exit hardware" labeled for rating up to and including 3 hours.
- Endurance test, over 500,000 time still keep good performance.
- Surface mounted for ease of installation.



| Accessories |
|---------------------------|
| Standard Schlage C Keyway |
| Roller Strike & Shim |
| Screw Pack |
| Thru Bolts 4 pk. |
| End Cap |



KD-F2100-A SS
Material: Stainless Steel Grade 304
Finish: SS



KD-F2100-A SL
Material: Iron
Finish: Silver

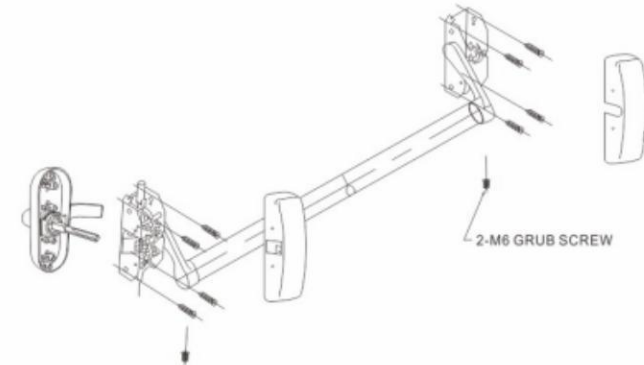

The push bar with integral lock combines proven mechanics with convenient assembly and operation. Available in various materials and designs, it allows for a multitude of applications. Technically up to corresponding to the new standard EN 1125, the touch bar is suitable for panic exit devices.



KD-F2000-B SN

- Material: Zinc alloy
- Finish: SS
- For: KD-F2100A

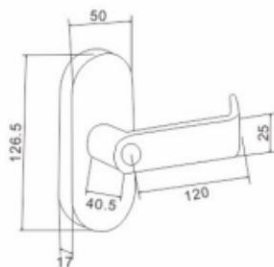

DS-001 SS

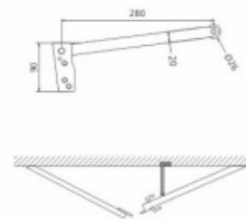

KD-F3000-B SC

- Material: Zinc alloy
- Finish: SC
- For: KD-F3000

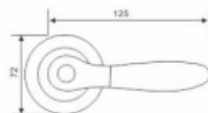

DS-002 SS

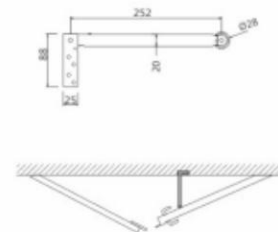

KD-F4000-B SS

- Material: Stainless Steel /Zinc alloy
- Finish: SS
- For: KD-F3160,F3300,F3400

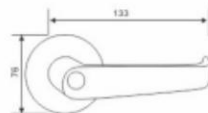

DS-003 SS



Character:

1. Close by one point.
2. Exposure type.
3. Semi length push bar.
4. Different length according to the width of door.
5. Different colors can be chosen.



AKADA

Euro Profile Mortise Lock



| ART.NO: | FINISH: |
|---------|---------|
| 8500-40 | GP |
| 8500-45 | SN |
| 8500-50 | PVD |
| 8500-55 | CP |
| 8500-60 | AB |
| 8500-70 | AC |
| 8500-80 | SS |

STANDARD LOCK

Features

For wooden & metal doors
 For single-leaf doors
 Prepared for profile cylinders
 With key action
 Stainless steel or brass latch bolt
 Deadbolt 2-tutns

Technical data

Follower 6mm
 Distance 65mm
 Backset 40, 45, 50, 55, 60, 70, 80mm

Forend

Type Square head/ round head
 Thickness 3mm
 Width 22mm

Forend finish

Steel: SN, CP, AB, AC, COF, PVD, SS, GP

Accessories

Striking plate
 Lock and striking plate fixing screws

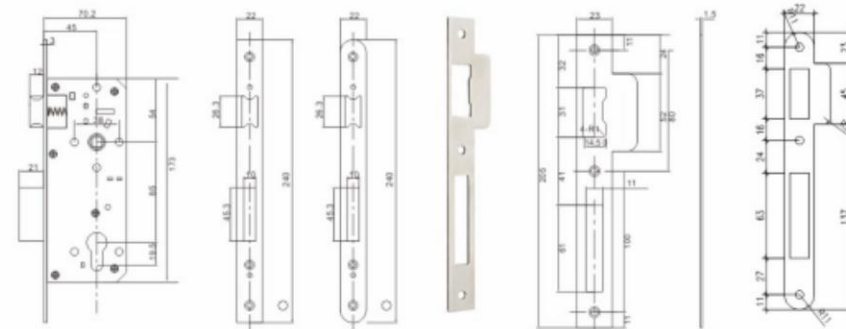



| ART.NO: | FINISH: |
|---------|---------|
| 8504-40 | SN |
| 8504-45 | GP |
| 8504-60 | CP |

STANDARD LOCK

Features

For wooden & metal doors
For single-leaf doors
Prepared for profile cylinders
With key action
Stainless steel or brass latch bolt
Deadbolt 2-tutns

Technical data

| | |
|----------|--------------|
| Follower | 8mm |
| Distance | 85mm |
| Backset | 40, 45, 60mm |

Forend

| | |
|-----------|-------------|
| Type | Square head |
| Thickness | 3mm |
| Width | 23mm |

Forend finish

Steel: SN, CP, AB, AC, COF, PVD, SS, GP

Accessories

Striking plate
Pocket
Lock and striking plate fixing screws



| ART.NO: | FINISH: |
|---------|---------|
| 8501-45 | SN |
| 8501-55 | GP |

STANDARD LOCK

Features

For wooden & metal doors
For single-leaf doors
Prepared for profile cylinders
With key action
Stainless steel or brass latch bolt
Deadbolt 2-tutns

Technical data

| | |
|----------|-----------|
| Follower | 8mm |
| Distance | 85mm |
| Backset | 45, 55 mm |

Forend

| | |
|-----------|-------------|
| Type | Square head |
| Thickness | 3mm |
| Width | 23mm |

Forend finish

Steel: SN, CP, AB, AC, COF, PVD, SS, GP

Accessories

Striking plate
Lock and striking plate fixing screws

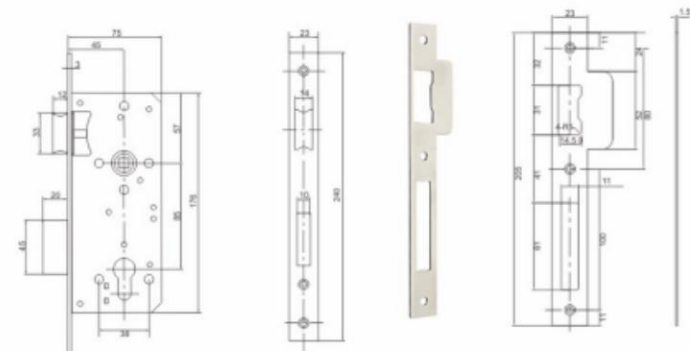
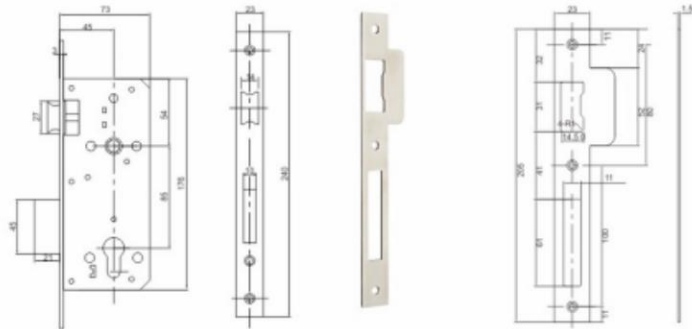



| ART.NO: | FINISH: |
|---------|---------|
| 8506-50 | SN |
| 8506-60 | SN |

STANDARD LOCK

Features

For wooden & metal doors
For single-leaf doors
Prepared for profile cylinders
With key action
Stainless steel or brass latch bolt
Deadbolt 2-tufts

Technical data

| | |
|----------|----------|
| Follower | 8mm |
| Distance | 85mm |
| Backset | 50, 60mm |

Forend

| | |
|-----------|-------------|
| Type | Square head |
| Thickness | 3mm |
| Width | 23mm |

Forend finish

Steel: SN, CP, AB, AC, COF, PVD, SS, GP

Accessories

Striking plate
Lock and striking plate fixing screws

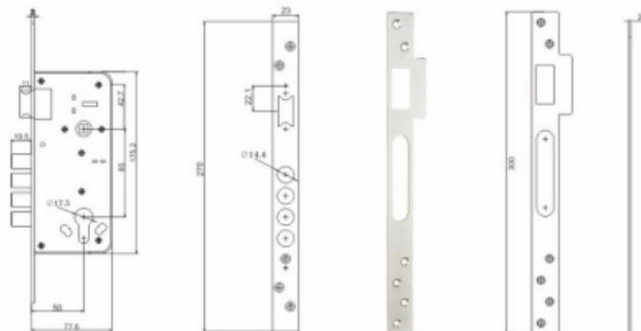

| ART.NO: | FINISH: |
|----------|---------|
| 7203-55 | SS |
| 7203-60 | SS |
| 7203-65 | SS |
| 7203-70 | SS |
| 7203-80 | SS |
| 7203-100 | SS |

STANDARD LOCK

Features

According to EN12209-Grade 3, DIN 18251-1
For wooden & metal doors
For single-leaf doors
Optional for rebated or non-rebated doors
Suitable for external fire and smoke doors
Prepared for profile cylinders
With key action
Stainless steel or brass latch bolt
Deadbolt 2-tufts

Technical data

| | |
|----------|---------------------------|
| Follower | 7, 8, 9mm |
| Distance | 72mm |
| Backset | 55, 60, 65, 70, 80, 100mm |

Forend

| | |
|-----------|------------------|
| Type | Square head |
| Thickness | 3mm |
| Width | 20, 22, 23, 24mm |

Forend finish

Steel: SN, CP, AB, AC, COF, PVD, SS, GP

Accessories

Striking plate
Lock and striking plate fixing screws

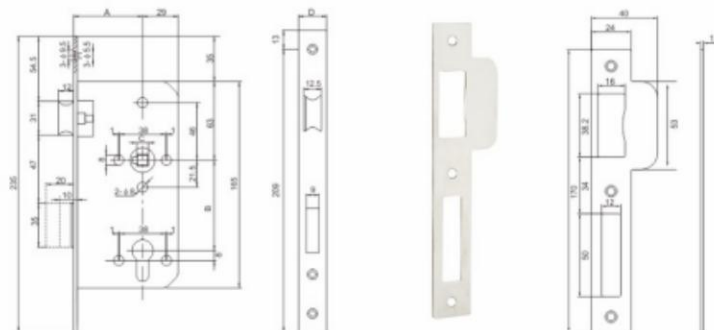



| ART.NO: | FINISH: |
|---------|---------|
| 8510-45 | SS |
| 8510-50 | SS |
| 8510-60 | SS |

STANDARD LOCK

Features

For wooden & metal doors
For single-leaf doors
Prepared for profile cylinders
With key action
Stainless steel or brass latch bolt
Deadbolt 2-tutns

Technical data

Follower 8mm
Distance 85mm
Backset 45, 50, 60mm

Forend

Type Square head
Thickness 3mm
Width 23mm

Forend finish

Steel: SN, CP, AB, AC, COP, PVD, SS, GP

Accessories

Striking plate
Lock and striking plate fixing screws

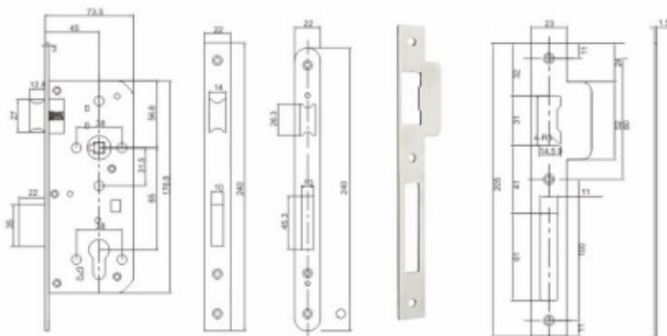

ART. NO.:
7200-55 SS

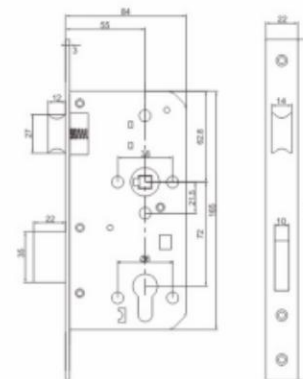

ART. NO.:
7800-55 SS

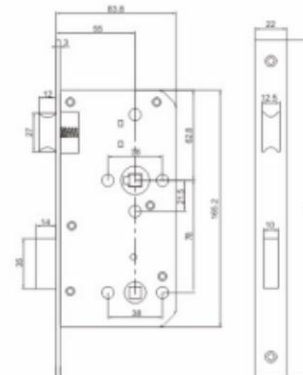



| ART.NO: | FINISH: |
|---------|---------|
| 8508-55 | SS |

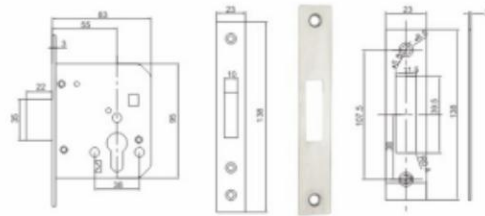

| ART.NO: | FINISH: |
|---------|---------|
| D58 | SS |

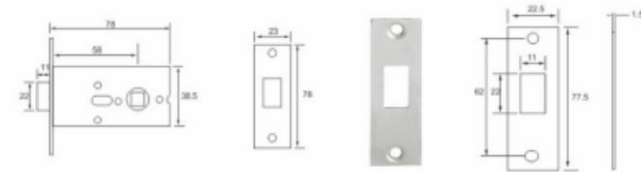

| ART.NO: | FINISH: |
|------------|---------|
| 8508-40-3R | SS |
| 8508-45-3R | SS |
| 8508-55-3R | SS |

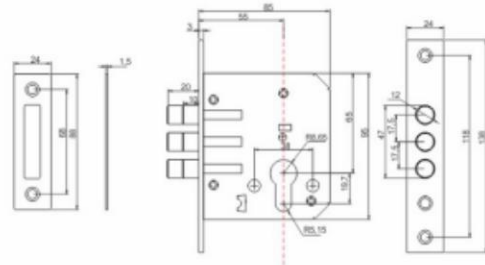

| ART.NO: | FINISH: |
|---------|---------|
| HL01-20 | SS |
| HL01-30 | SS |
| HL01-40 | SS |
| HL01-50 | SS |
| HL01-60 | SS |

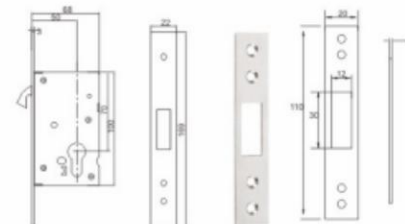



| ART.NO: | FINISH: |
|---------|---------|
| 8540-45 | SS |
| 8540-50 | SS |

STANDARD LOCK

Features

For wooden & metal doors
For single-leaf doors
Stainless steel or brass latch bolt
Deadbolt 1-turns

Technical data

| | |
|----------|---------|
| Follower | 8mm |
| Distance | 85mm |
| Backset | 45,50mm |

Forend

| | |
|-----------|-------------|
| Type | Square head |
| Thickness | 3mm |
| Width | 22,23mm |

Forend finish

Steel: SN, CP, AB, AC, COF, PVD, SS, GP

Accessories

Striking plate
Lock and striking plate fixing screws



| ART.NO: | FINISH: |
|---------|---------|
| 8541-40 | SS |
| 8541-45 | SS |
| 8541-50 | SS |

STANDARD LOCK

Features

For wooden & metal doors
For single-leaf doors
Prepared for profile cylinders
With key action
Stainless steel or brass latch bolt
Deadbolt 2-turns

Technical data

| | |
|---------|------------|
| Backset | 40,45,50mm |
|---------|------------|

Forend

| | |
|-----------|-------------|
| Type | Square head |
| Thickness | 3mm |
| Width | 22mm |

Forend finish

Steel: SN, CP, AB, AC, COF, PVD, SS, GP

Accessories

Striking plate
Pocket
Lock and striking plate fixing screws

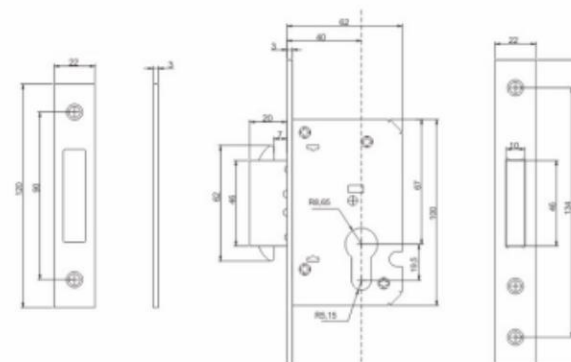



| ART.NO: | FINISH: |
|---------|---------|
| 8529-20 | CP |
| 8529-25 | CP |
| 8529-30 | SN |
| 8529-35 | SN |

STANDARD LOCK

Features

For wooden & metal doors
For single-leaf doors
Prepared for profile cylinders
With key action
Stainless steel or brass latch bolt
Deadbolt 1-turns

Technical data

Follower 8mm
Distance 85mm
Backset 20, 25, 30, 35mm

Forend

Square head
Thickness 3mm
Width 22mm

Forend finish

Steel: SN, CP, AB, AC, COF, PVD, SS, GP

Accessories

Striking plate
Lock and striking plate fixing screws



ART. NO.:
8509-20 CP

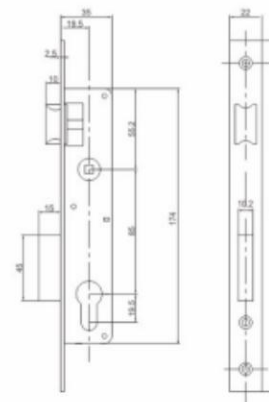

ART. NO.:
8509-30 SN

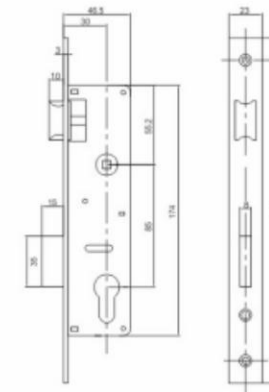



ART. NO.:
7213BK-40 SN

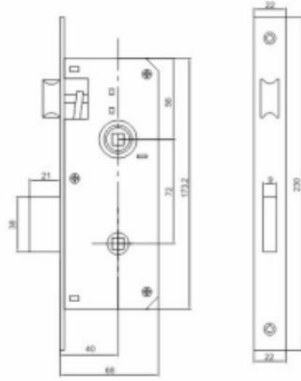

ART. NO.:
7213BK-45 SN

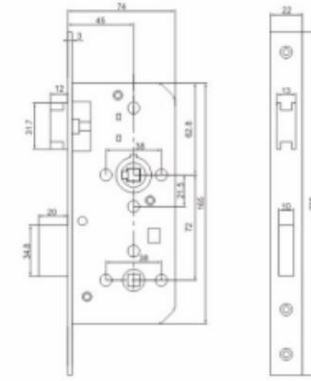

ART. NO.:
7213BB-40 SN



ART. NO.:
7213BB-45 SN

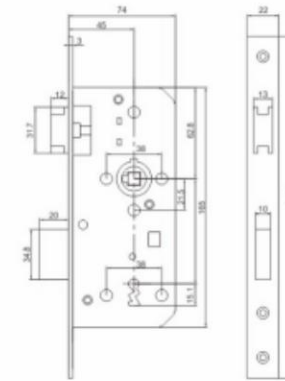

AKADA[®]

Euro Profile Cylinder

Core element of our product range are locking systems. Generally speaking, a locking system comprises a number of different cylinders that can be operated by one or several high-order keys or a system including central cylinders (e.g. entrance doors of buildings) that can be operated by a number of different keys (e.g. the keys to the individual apartment doors).

Four aspects must be considered when designing a locking system:

Security

Absolute key control: key blanks are not available in the trade. Additional keys can only be ordered upon presentation of the security card. This prevents any unauthorised duplication of keys. The clear allocation of individual keys to defined persons significantly enhances the security.

Convenience

Instead of many keys, only one key is needed for all doors that a given person is permitted to open.

Organization

A locking system can also be used to design processes within an organization. The corporate hierarchy can thus be translated into access authorizations.

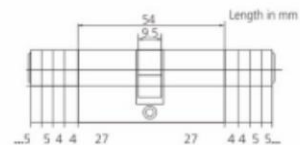

| A/mm | B/mm | Total length |
|------|------|--------------|
| 10 | 35 | 45 |
| 27 | 27 | 54 |
| 30 | 30 | 60 |
| 31.5 | 31.5 | 63 |
| 35 | 35 | 70 |
| 30 | 40 | 70 |
| 40 | 40 | 80 |
| 30 | 50 | 80 |
| 45 | 45 | 90 |
| 30 | 60 | 90 |
| 50 | 50 | 100 |
| 30 | 70 | 100 |
| ... | ... | ... |
| ... | ... | ... |

Further lengths are possible.
Maximum total length 200 mm.

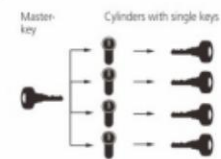
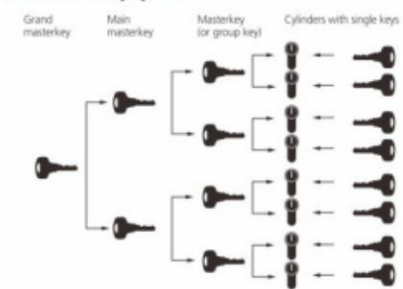
Central Locking System**Simple Masterkey System****Grand Masterkey System****Finish**

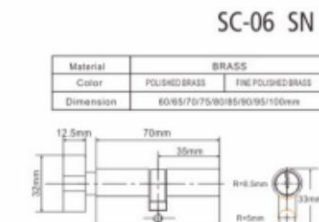
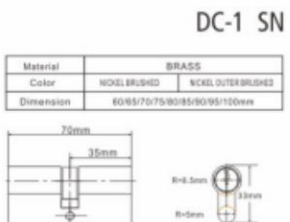
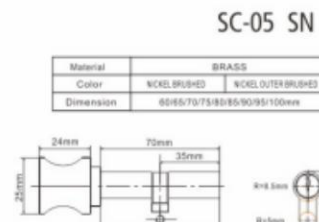
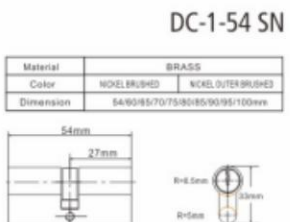
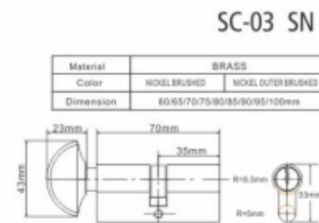
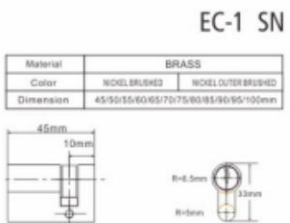

NEW

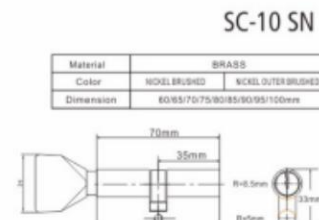
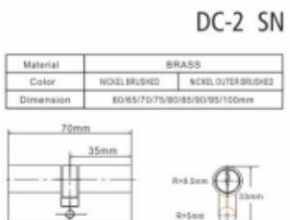



CDC-1 SN

| | | |
|-----------|-------------------------------------|----------------------|
| Material | BRASS | |
| Color | NICKEL BRUSHED | NICKEL OUTER BRUSHED |
| Dimension | 45/55/65/85/70/75/80/85/90/95/100mm | |



CSC-03 PB

| | | |
|-----------|-------------------------------|----------------------|
| Material | BRASS | |
| Color | NICKEL BRUSHED | NICKEL OUTER BRUSHED |
| Dimension | 60/65/70/75/80/85/90/95/100mm | |

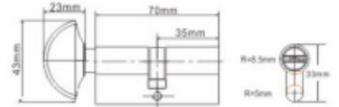

CSC-05 SN

| | | |
|-----------|-------------------------------|----------------------|
| Material | BRASS | |
| Color | NICKEL BRUSHED | NICKEL OUTER BRUSHED |
| Dimension | 60/65/70/75/80/85/90/95/100mm | |

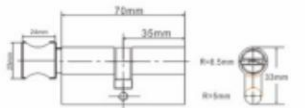

CSC-06 SN

| | | |
|-----------|-------------------------------|----------------------|
| Material | BRASS | |
| Color | NICKEL BRUSHED | NICKEL OUTER BRUSHED |
| Dimension | 60/65/70/75/80/85/90/95/100mm | |

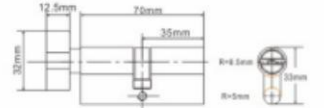

CSC-10 SN

| | | |
|-----------|-------------------------------|----------------------|
| Material | BRASS | |
| Color | NICKEL BRUSHED | NICKEL OUTER BRUSHED |
| Dimension | 60/65/70/75/80/85/90/95/100mm | |

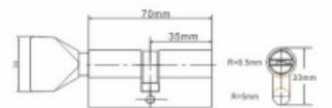

DT-7 SN

| | | |
|-----------|-------------------------------|---------------------|
| Material | BRASS | |
| Color | BRASS BRUSHED | BRASS THICK BRUSHED |
| Dimension | 60/65/70/75/80/85/90/95/100mm | |

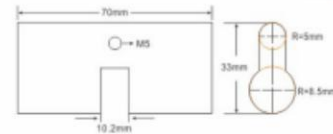

ATD-9 SN

| | | |
|-----------|-------------------------|---------------------|
| Material | BRASS | |
| Color | BRASS BRUSHED | BRASS THICK BRUSHED |
| Dimension | 70/75/80/85/90/95/100mm | |

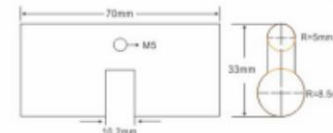



BC-01 CP

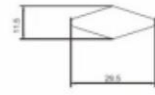

BC-02 AC

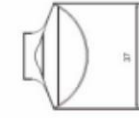

BC-03 SC

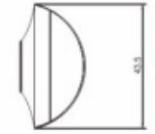

BC-04 AB

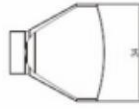

BC-05 SN

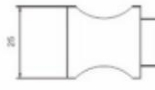

BC-06 SN



BC-07 PB

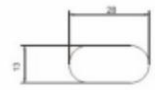

BC-08 BB

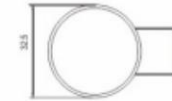

BC-09 SN



BC-10 SN



BC-11 SN

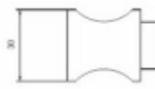

BC-12 BB



K02



K08



K10



K14



K15



K20



K27



K28



K29



K30



K31



K32



K33



K34



K35



K36



K37



K38



K39



K40



K41



K42



K43



K44



K45



K46



K47



K48



K49



K50



K51



K52



K53



K54



K55